

LOCATION: Grand Ave -- Weldon Ave
CITY/STATE: Oakland, CA

QC JOB #: 13350909
DATE: Thu, Apr 23 2015

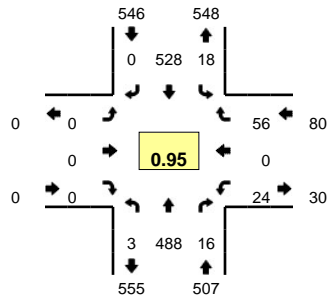

Peak-Hour: 8:00 AM -- 9:00 AM
Peak 15-Min: 8:45 AM -- 9:00 AM

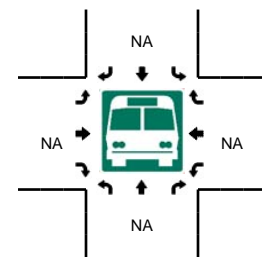
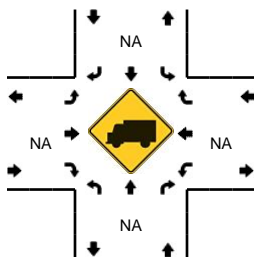
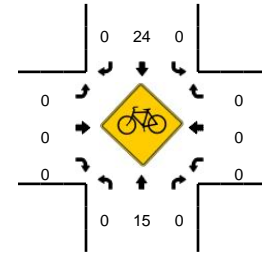
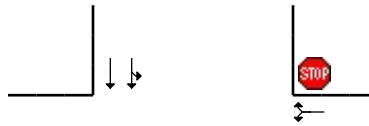
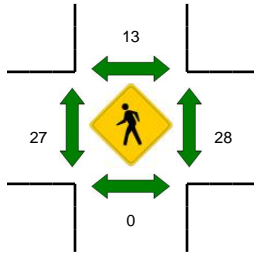
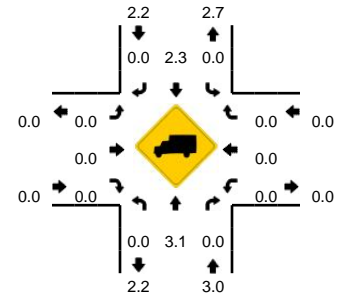

5-Min Count Period Beginning At	Grand Ave (Northbound)				Grand Ave (Southbound)				Weldon Ave (Eastbound)				Weldon Ave (Westbound)				Total	Hourly Totals
	Left	Thru	Right	U	Left	Thru	Right	U	Left	Thru	Right	U	Left	Thru	Right	U		
7:00 AM	0	15	2	0	0	18	0	0	0	0	0	0	0	0	0	0	35	
7:05 AM	0	17	0	0	0	20	0	0	0	0	0	0	2	0	0	0	39	
7:10 AM	0	17	2	1	0	19	0	0	0	0	0	0	4	0	1	0	44	
7:15 AM	0	22	1	0	0	17	0	0	0	0	0	0	2	0	2	0	44	
7:20 AM	0	20	1	0	0	17	0	0	0	0	0	0	3	0	0	0	41	
7:25 AM	0	23	2	0	0	15	0	0	0	0	0	0	2	0	1	0	43	
7:30 AM	0	24	2	0	0	20	0	0	0	0	0	0	1	0	0	0	47	
7:35 AM	0	29	1	0	0	21	0	0	0	0	0	0	7	0	2	0	60	
7:40 AM	0	24	2	0	1	32	0	0	0	0	0	0	1	0	2	0	62	
7:45 AM	0	32	0	0	1	36	0	0	0	0	0	0	1	0	4	0	74	
7:50 AM	0	38	2	0	1	21	0	0	0	0	0	0	2	0	3	0	67	
7:55 AM	0	30	2	0	1	32	0	0	0	0	0	0	3	0	3	0	71	627
8:00 AM	0	40	1	0	0	34	0	0	0	0	0	0	2	0	2	0	79	671
8:05 AM	0	36	0	0	1	48	0	0	0	0	0	0	3	0	4	0	92	724
8:10 AM	0	40	0	0	0	36	0	1	0	0	0	0	2	0	10	0	89	769
8:15 AM	0	40	1	0	1	49	0	0	0	0	0	0	2	0	8	0	101	826
8:20 AM	0	46	0	0	0	35	0	0	0	0	0	0	2	0	9	0	92	877
8:25 AM	0	46	0	0	1	49	0	0	0	0	0	0	2	0	4	0	102	936
8:30 AM	0	36	3	0	1	42	0	0	0	0	0	0	1	0	4	0	87	976
8:35 AM	0	33	0	0	1	56	0	0	0	0	0	0	3	0	5	0	98	1014
8:40 AM	0	41	4	0	2	45	0	1	0	0	0	0	1	0	2	0	96	1048
8:45 AM	0	38	1	1	2	51	0	1	0	0	0	0	1	0	4	0	99	1073
8:50 AM	0	43	3	2	4	41	0	0	0	0	0	0	3	0	1	0	97	1103
8:55 AM	0	49	3	0	1	42	0	1	0	0	0	0	2	0	3	0	101	1133
Peak 15-Min Flowrates	Northbound				Southbound				Eastbound				Westbound				Total	
	Left	Thru	Right	U	Left	Thru	Right	U	Left	Thru	Right	U	Left	Thru	Right	U		
All Vehicles	0	520	28	12	28	536	0	8	0	0	0	0	24	0	32	0	1188	
Heavy Trucks	0	8	0	0	0	8	0	0	0	0	0	0	0	0	0	0	16	
Pedestrians		0				20				20				40			80	
Bicycles	0	4	0		0	9	0		0	0	0		0	0	0		13	
Railroad																		
Stopped Buses																		

Comments: